

TECHNIFLO

Chemical & Process Pump Range



Contents

Introduction	2
TB Series	3
U-Mag Series	8
PW-C Series	11
PW Series	13
PW-N Self-Priming Series	15
PX & PS Series	16
Accessories, Mixers and Drum Pumps	18

Introduction

TECHNIFLO is a complete range of non-metallic sealless mag-drive centrifugal pumps. "Sealless Magnetic Drive" means zero leakage. Techniflo pumps have no mechanical seals or packed glands. Fluid is hermetically sealed from the driving end and the driving power is transmitted via magnetic force with powerful synchronous magnets. All of the wetted parts in a Techniflo pump are chemically resistant and various combinations of engineered plastics, high grade ceramics, silicon carbide, and carbons are available depending on the application.

▪ Leading Edge Technology

Techniflo is the product of over 30 years experience in Non-Metallic centrifugal pump design, featuring state-of-the-art thrust balance technology and advanced manufacturing procedures.

▪ Designed for the Worst

Designed for extended use in the most difficult duties, Techniflo pumps can be used with confidence on a full range of extremely corrosive, hazardous, toxic, explosive and dangerous chemicals.

▪ Quality Tested, Proven Reliability and Performance

Manufactured to the highest standards with a premium on Quality Control, every Techniflo pump is factory-tested to verify operational performance. Years of extended service in numerous installations are a testimony to the exceptional quality and reliability of Techniflo.

▪ Rewards and Benefits

With the interests of every pump user in mind, Techniflo delivers a number of significant rewards and benefits:

- Exceptional quality and economic prices
- Low operational and lifetime costs
- Reduced downtime and increased production
- Ease of maintenance
- User health and safety
- Operator confidence
- Environmental protection



TB Series



Typical Applications

- Petrochemical industry
- Volatile & low flashpoint liquids
- Mineral processing
- Chemical manufacturing
- Chemical processing
- Steel making industry
- Heat transfer liquids
- Hot liquors
- Bio-diesel plants
- Fertiliser plants

Technical Features

- Heavy duty ductile casing with bonded PTFE lining
- Patented world first thrust balanced design (see page 5)
- Completely open impeller eye on all models for optimum NPSHr and efficiency
- One bolt size for ease of maintenance
- Close-coupled and bare shaft versions
- ANSI 150 flanges
- Fluid temperatures from -70°C to 121°C
- System pressures up to 20.7 bar (300psi)
- Conforming with ASME/ANSI B73.1 M footprint
- Back pullout design - liquid end and drive end independently serviceable
- Flows up to 300m³/hr
- Heads up to 100m
- Liquid SG up to 2.5
- Rare-earth magnets on all pumps
- Secondary containment design available
- Epoxy resin paint finish with all AAPU top coat
- Two bolt flanged drain, with optional tapping
- 100% replacement wearing parts



TB Series

Technical Illustration

Outer Magnet Assembly

- One drive size per motor frame. Simple keyless design means assembly with motor shaft is quick and easy.
- Magnets bolted and sealed inside 316 stainless steel carrier.

Containment Shell

- One-piece carbon fibre Teflon® moulding for a combination of strength and chemical resistance.
- Patented reinforced socket for shaft mounting. Outer pressure housing made from a Kevlar® composite.

Radial Bearings

- Dual carbon graphite or sintered silicon carbide.
- Individually replaceable and flexibly-mounted for full alignment with shaft.

Impeller/Mag Capsule

- Unique one-piece design with magnets potted and sealed inside 316 stainless steel cover, and all encapsulated in Teflon® for optimum chemical resistance.

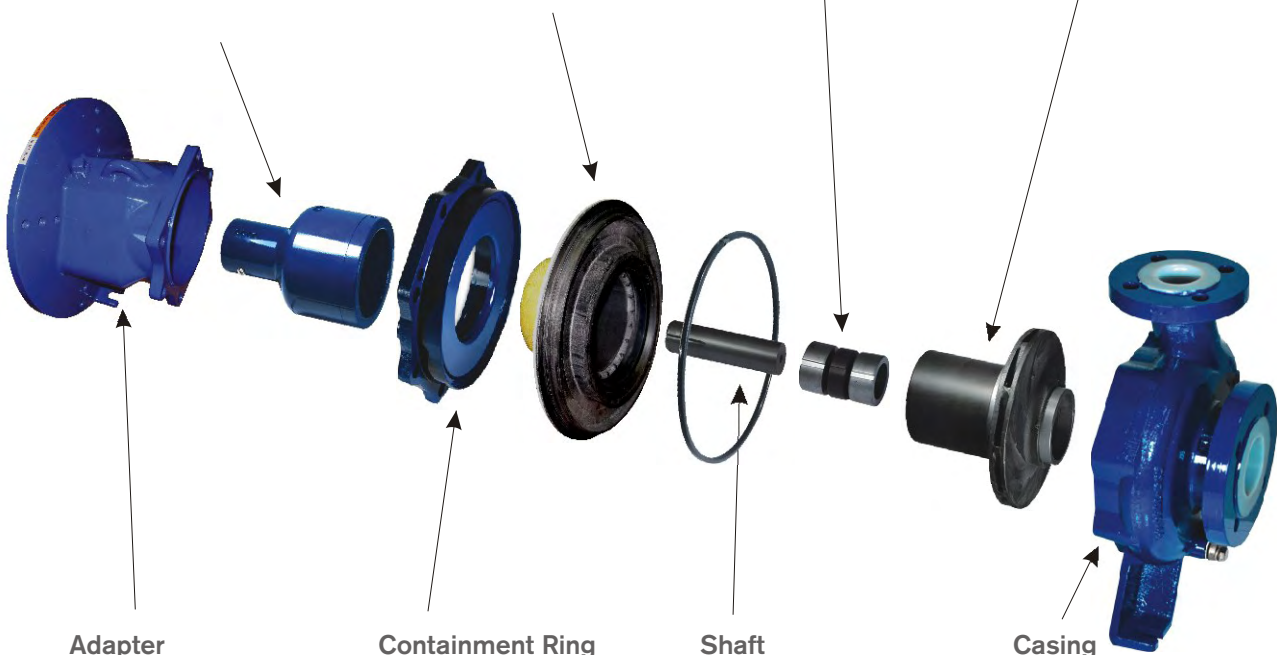

Adapter

- Mates flanged motors to the pump. Can mount a range of sizes directly without spacer plates. Integral foot mates to existing ANSI base plates.
- All mounting bolts conveniently accessed from outside the adapter to simplify motor/pump mating.

Containment Ring

- Extra heavy-duty one-piece cast ductile iron casting.
- Precisely aligns and supports the containment shell in the casing.
- Is separate from the adapter to allow servicing motor without opening the liquid end of the pump.

Shaft

- Replaceable, straight, sintered silicon carbide shaft cantilevered from the containment shell.
- Oversized to safely handle all load combinations.
- Cantilever design leaves impeller suction open for best possible performance.

Casing

- Top centreline discharge, one-piece cast ductile iron with bonded Teflon® lining. Lining minimum of 1/8" (3.175mm).
- Provides nearly universal corrosion resistance and extremely low maintenance.
- Casing drain is standard.

TB Series

Unique Patented Thrust Balancing Feature

The TB Series 'Thrust Balancing' is a revolutionary engineering concept.

As seen in Fig.1, the discharge pressure causes liquid to flow past the clearance rings and around the Magnet Capsule. At higher flows the variable orifice opens and decreases the balance pressure to negate forward thrust of the impeller.

At lower flows the variable orifice closes and increases the balance pressure to negate the back-thrust of the impeller.

The net result is an extremely stable axial position that does not require thrust bearings.

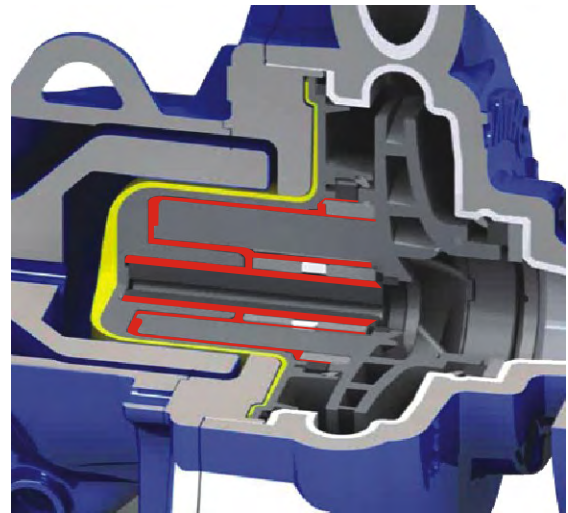

Figure 1

Clearance Rings & Solids

TB Series clearance rings restrict solids greater than 0.1mm from entering the containment shell area keeping all bearings and critical flow paths clear. This enables the pump to successfully handle solids. Concentrations up to 30% and particle sizes to 6mm in size are possible.

Pressurised Radial Bearings & Volatile Liquids

The TB Series radial bearings operate in a pressurised fluid environment, which enables volatile liquids to be pumped safely without flashing off.

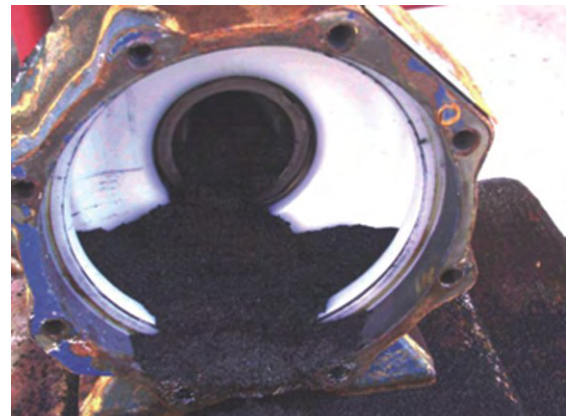
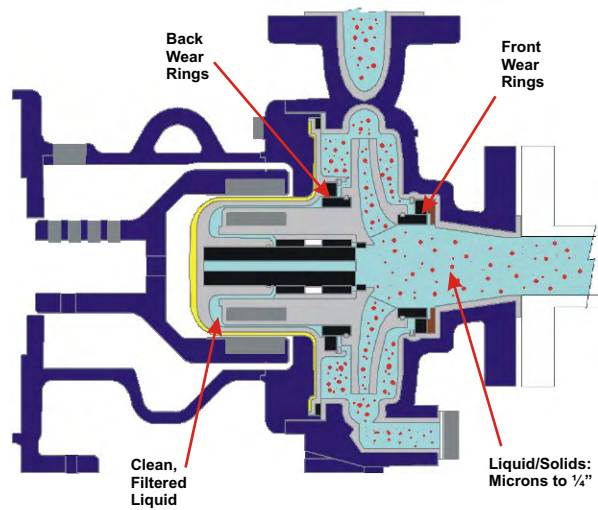

65% Carbon Slurry application after 11 months of operation

TB Series

Performance Curves

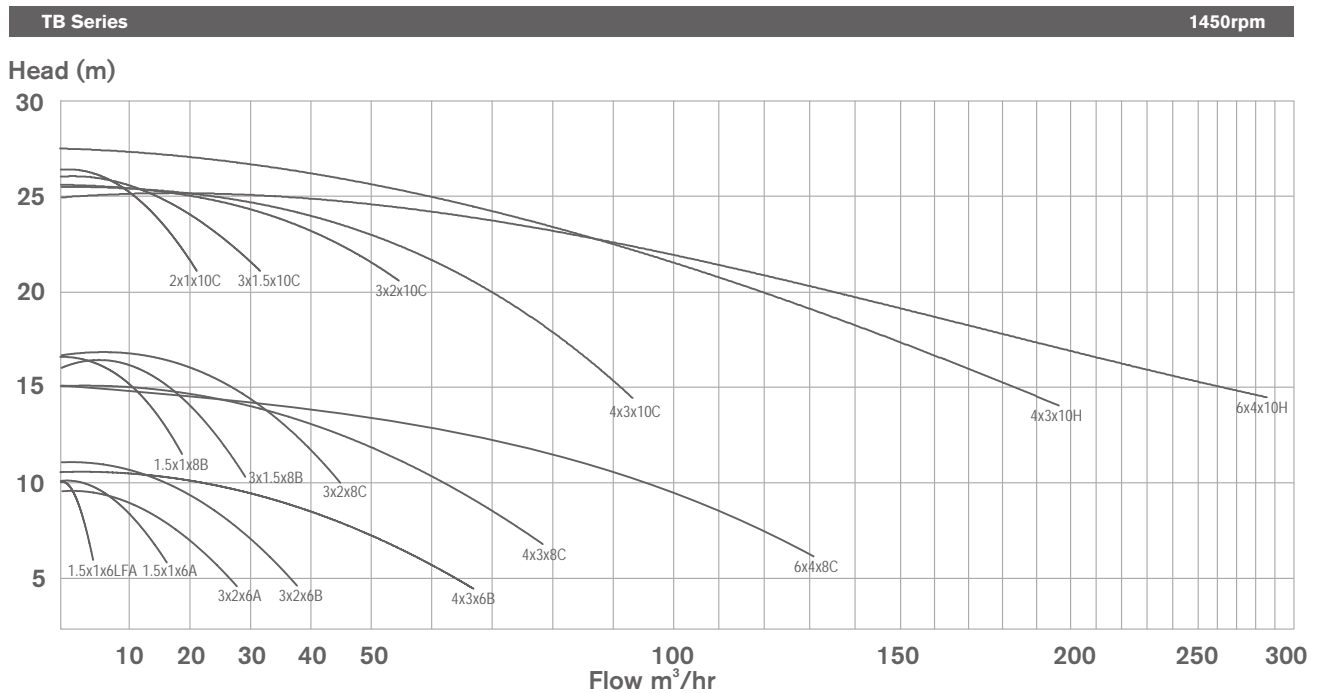
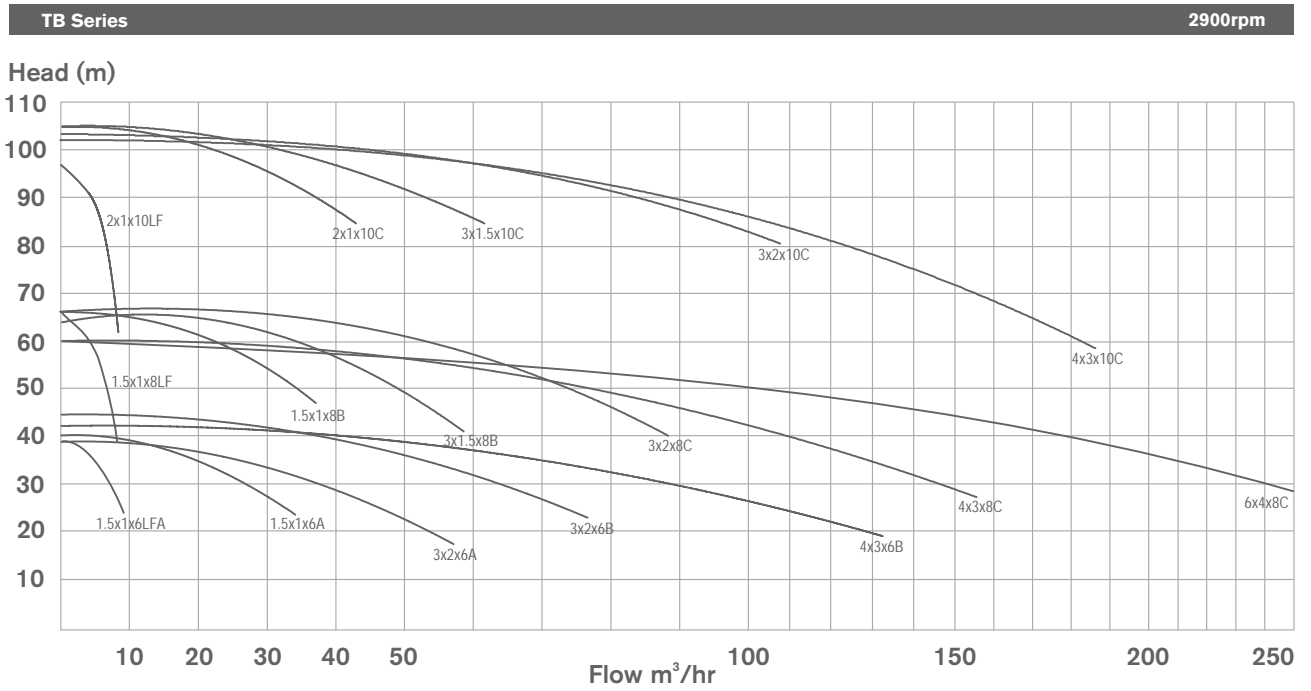

TB Series

Dimensions

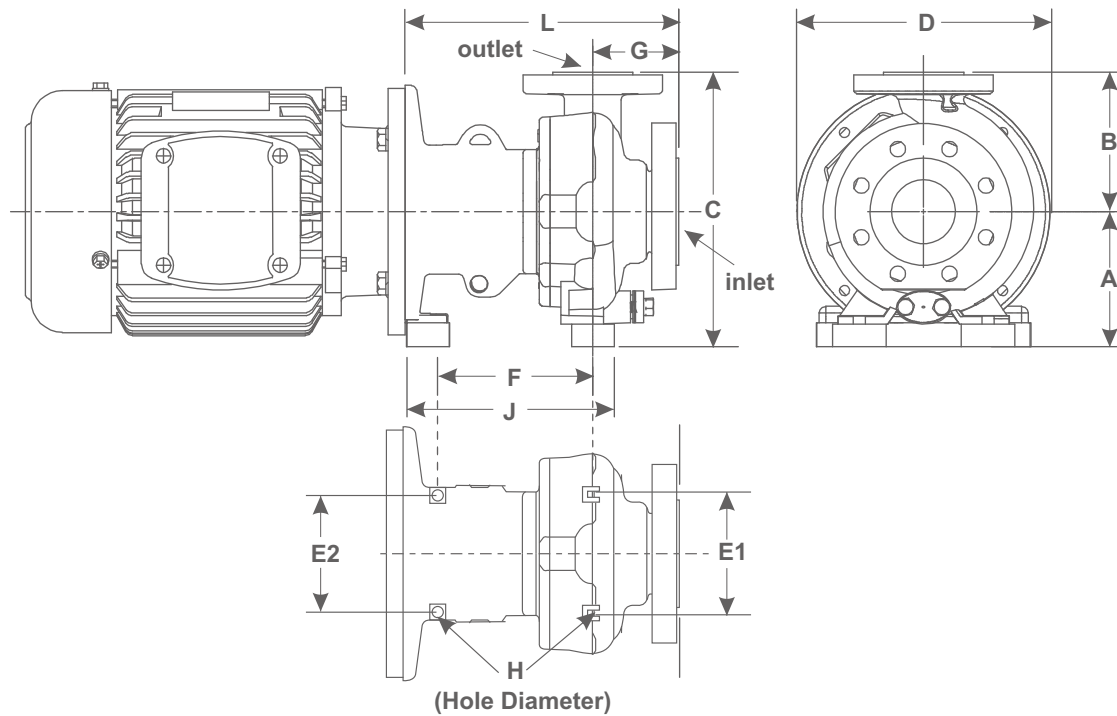

Pump Size	A	B	C	D	E1	E2	F	G	H	J	L	inlet/outlet	Bare Pump kg
1.5 x 1 x 6A	133	165	298	300	152	0	184	102	16	221	370	40/25	34
3 x 2 x 6A	133	165	298	300	152	0	184	102	16	287	324	80/50	39
1.5 x 1 x 8B	133	165	298	300	152	0	184	102	16	287	394	40/25	59
3 x 2 x 6B	210	209	419	281	248	184	318	102	16	312	394	80/50	63
3 x 1.5 x 8B	210	216	425	316	248	184	318	102	16	287	414	80/40	64
4 x 3 x 6B	210	209	419	350	248	184	318	102	16	287	414	100/80	75
3 x 2 x 8C	210	241	451	306	248	184	318	102	16	287	414	80/50	67
4 x 3 x 8C	210	279	489	372	248	184	318	102	16	287	414	100/80	83
2 x 1 x 10C	210	216	425	351	248	184	318	102	16	287	414	50/25	93
3 x 1.5 x 10C	210	216	425	361	248	184	318	102	16	287	414	80/40	96
3 x 2 x 10C	210	241	451	306	248	184	318	102	16	287	414	80/50	101
4 x 3 x 10C	210	279	489	372	248	184	318	102	16	287	414	100/80	107
4 x 3 x 10HC	210	279	489	372	248	184	318	102	16	287	414	100/80	113
6 x 4 x 8C	254	343	597	477	248	184	318	102	16	287	414	150/100	113
6 x 4 x 10C	254	343	597	477	248	184	318	102	16	287	414	150/100	116

NOTE: Pump flanges are ANSI 150. Other drillings are available on request.

Explosion-proof motors are available on request.

Motor dimensions will vary depending on size and type used.

All dimensions in millimetres.

U-Mag Series

The U-mag series is made with the exact same high quality materials as the TB-mag, but designed for smaller and more refined applications.

The U-mag series is offered in a variety of fluoroplastic materials, including High Purity PFA for ultra low contaminants (ppb).

Technical Features

- Compact, heavy-duty, non-metallic magnetic drive pump.
- Universal flange design - meets ANSI, ISO and JIS piping connections.
- Fluoroplastic ETFE and Ultra High Purity PFA provide universal chemical compatibility.
- Powerful neodymium magnets provide maximum torque up to 10.5kW.
- Pump housing based on modified concentric volute to minimize radial loads and help extend bearing life.
- Cantilevered pump shaft allows for full opened pump suction, providing for the lowest NPSHr.
- Designed for easy pump service.
- Liquid end and drive end independently serviceable.
- 100% replaceable wear parts including all rotating and stationary rings.
- Flows to 102 m³/hr.
- Heads to 50m.



U-Mag Series

Technical Illustration

Adapter

- One-piece ductile iron casting.
- Mounts to IEC motors.
- Includes (3) 1/2" NPT access ports for optional monitoring.
- Zero alignment required.
- Universal foot supports entire pump load.

Containment Ring

- Extra heavy-duty, one-piece ductile iron casting.
- Separate from the adapter to allow servicing of the motor without opening the liquid end of the pump.
- Precisely aligns and supports the containment shell in the casing.

O-Ring Gasket

- Replaceable FEP / FKM O-ring standard. Provides universal chemical resistance.
- Square cross section: more sealing surface than traditional O-rings.
- Optional Materials are FKM (Fluorocarbon) or EPDM. Others available upon request.

Impeller

- Molded one-piece enclosed impeller made of carbon fibre-reinforced ETFE or PFA.
- High-strength neodymium iron boron magnet assembly.
- Magnet assembly hermetically sealed by Patented "Tru-Seal" Design.
- High efficiency, low NPSHr impeller geometry.



Outer Magnet

- One outer drive per motor frame size.
- Dowel pins eliminate motor shaft key for quick and easy install.
- Center "drill & tap" thread for easy removal from motor shaft.

Containment Shell

- Particulate control ring helps to protect radial bearing and containment shell from solids.
- Reinforced socket for pump shaft.
- Outer pressure housing made of Aramid composite for high pressure, strength and shock resistance.

Bearing

- Simple, reliable single bearing system made of carbon graphite or pure sintered silicon carbide (SiC).

Casing

- One-piece cast ductile iron.
- Flanges are slotted as standard, fits ANSI connections (other options available).
- Bonded ETFE or PFA lining, minimum of 3mm thickness.
- Optional two bolt flanged 1/2" drain with pure PTFE gasket and 316 SS blind flange.

U-Mag Series

Performance Curve

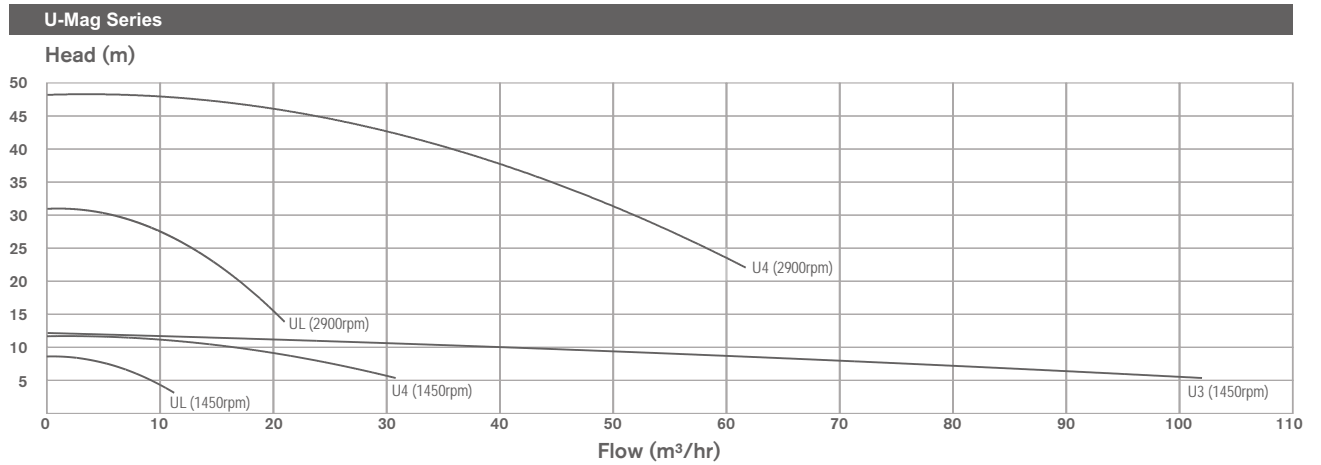

Dimensions

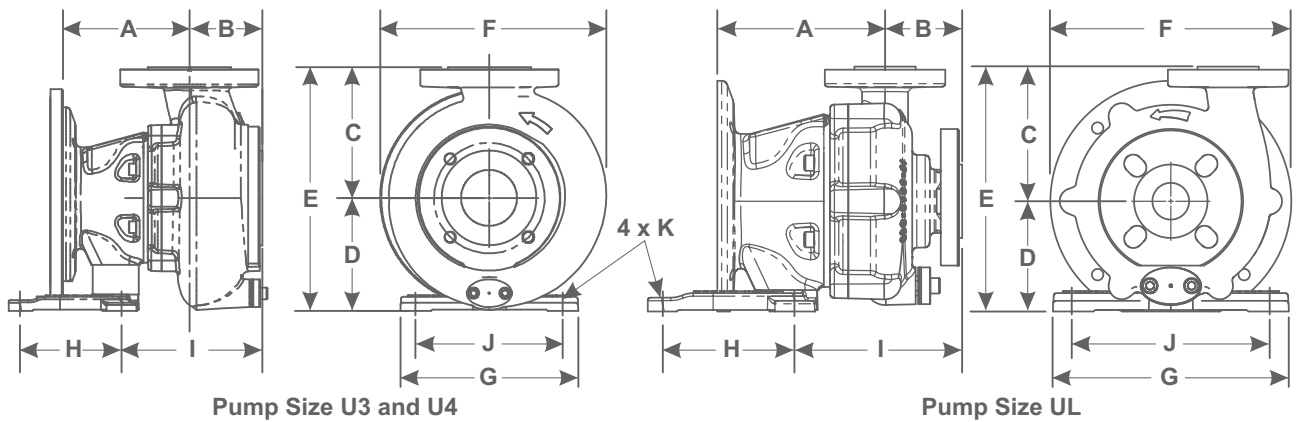

Pump Size	FRAME	A	B	C	D	E	F	G	H	I	J	K	inlet/ outlet	Bare Pump kg
UL - 1.5x1x5	80/90L	169	80	140	114	254	250	245	140	174	203	14	38/25	25
	100L/112M	174	80	140	155	295	250	245	140	174	203	14	38/25	25
	132	191	80	140	155	295	250	245	140	174	203	14	38/25	25
U3 - 3x2.5x6	80/90L	169	100	180	155	335	311	245	140	194	203	14	76/64	41
	100L/112M	174	100	180	155	335	311	245	140	194	203	14	76/64	41
	132	191	100	180	155	335	311	245	140	194	203	14	76/64	41
U4 - 2.5x2x6	80/90L	169	80	160	155	315	300	245	140	174	203	14	64/50	36
	100L/112M	174	80	160	155	315	300	245	140	174	203	14	64/50	36
	132	191	80	160	155	315	300	245	140	174	203	14	64/50	36

NOTE: Pump flanges are ANSI 150. Other drillings are available on request.
 Explosion-proof motors are available on request.
 Motor dimensions will vary depending on size and type used.
 All dimensions in millimetres.

PW-C Series



Typical Applications

- Water treatment plants
- Tanker unloading
- Battery industry
- Metal etching

- Pulp & paper industry
- Chemical refining
- Mineral processing

Technical Features

- Heavy-duty cast iron casing with moulded EFTE liner for extreme chemical resistance
- Closed-coupled IEC standard motors
- Flows up to 1500 L/min
- Heads up to 44 m
- Liquid SG up to 1.9
- Liquid temperatures up to 90°C
- Choice of bearing and shaft materials
- Flanged ports with universal bolt pattern to match Table E, DIN or ANSI 150
- Rare-earth magnets above 2.2kW motor size
- Epoxy resin paint finish



PW-C Series

Performance Curve

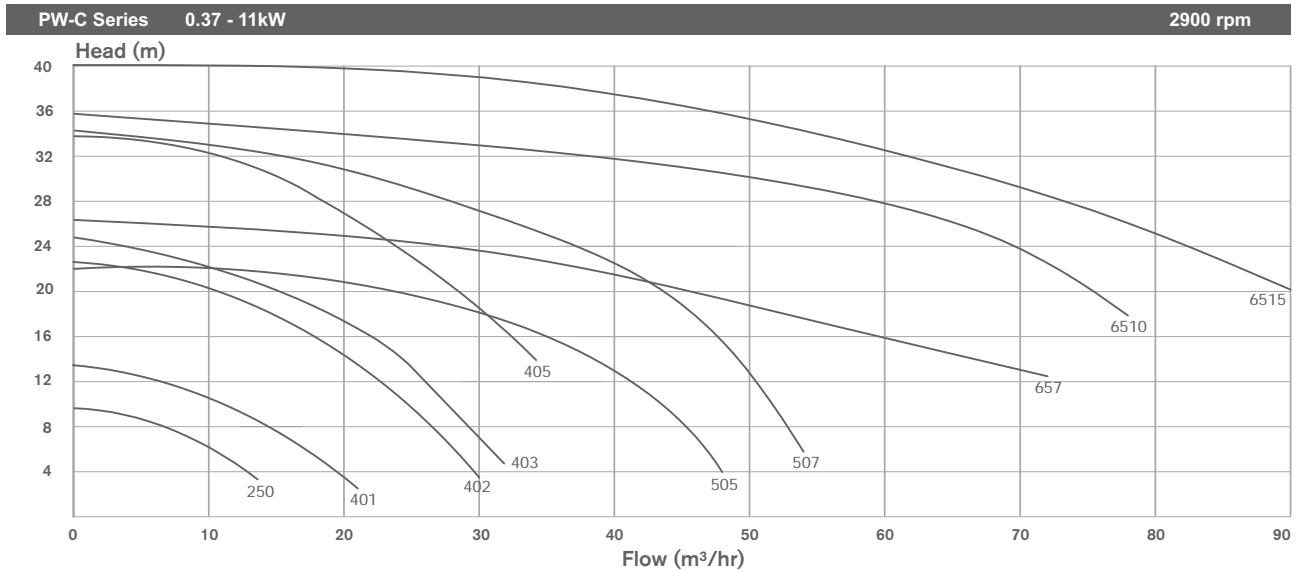

Dimensions

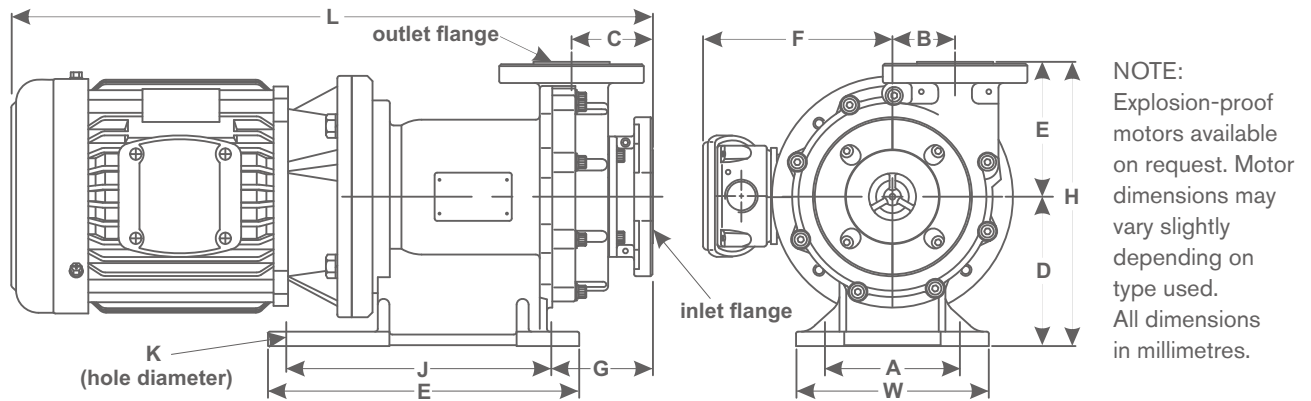

Model	W	H	L	A	B	C	D	E	F	G	J	K	inlet/ outlet	motor size
250PW-C	155	237	490	110	51	88	115	122	147	95	146	14	25/25	0.37kW
401PW-C	195	275	528.5	130	57.5	104.5	135	140	152	111	250	14	40/40	0.75kW
402PW-C	200	295	603	140	65	87	155	140	166	106	275	14	50/40	1.5kW
403PW-C	200	295	603	140	65	87	155	140	166	106	275	14	50/40	2.2kW
405PW-C	200	295	675.5	140	65	87	155	140	188	106	275	14	50/40	4.0kW
505PW-C	260	325	720	210	62	110	175	150	188	130	305	14	65/50	4.0kW
507PW-C	260	325	786	210	62	110	175	150	261	130	305	14	65/50	5.5kW
657PW-C	280	360	797.5	220	0	118	175	185	261	193	320	14	80/50	5.5kW
6510PW-C	280	360	797.5	220	0	118	175	185	261	193	320	14	80/50	7.5kW
6515PW-C	350	385	983.5	300	0	118	200	185	281	193	320	14	80/50	11.0kW

PW Series



Typical Applications

- PCB machines
- Electroplating solutions
- Fume scrubbers
- Salt & brine recirculation
- CIP cleaning systems
- Deionizing equipment
- Mineral processing solutions
- Bulk tank unloading

Technical Features

- Polypropylene and ETFE wet ends
- Closed-coupled IEC standard motors
- Flows up to 1400 L/min
- Heads up to 37 m
- Liquid SG up to 1.9
- Liquid temperatures
70°C for polypropylene
90°C for ETFE
- Flanged ports with universal bolt pattern to match Table E, DIN or ANSI 150
- Rare-earth magnets above 2.2kW motor sizes
- Self-priming versions up to 4kW (see page 15)

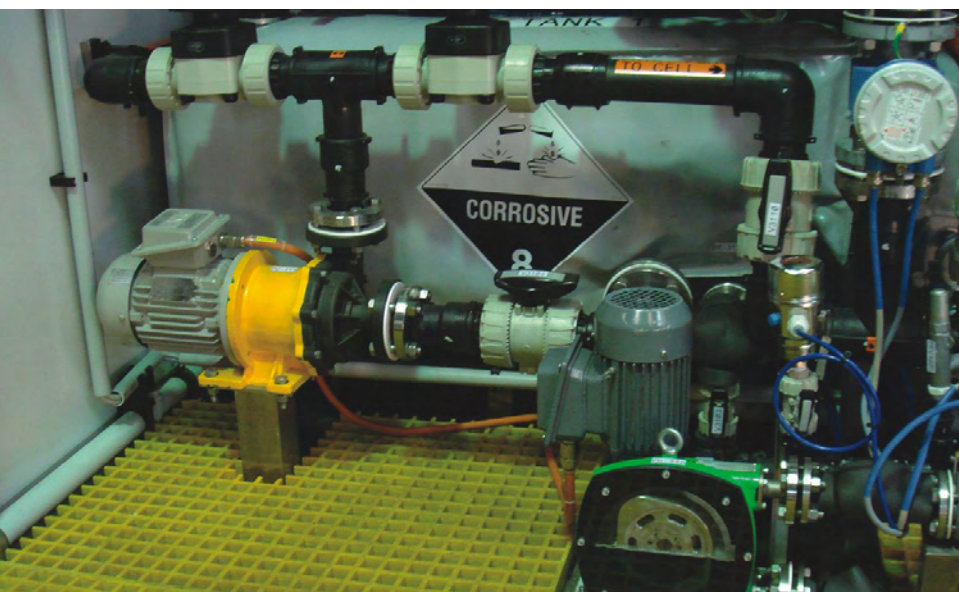

PW Series

Performance Curve

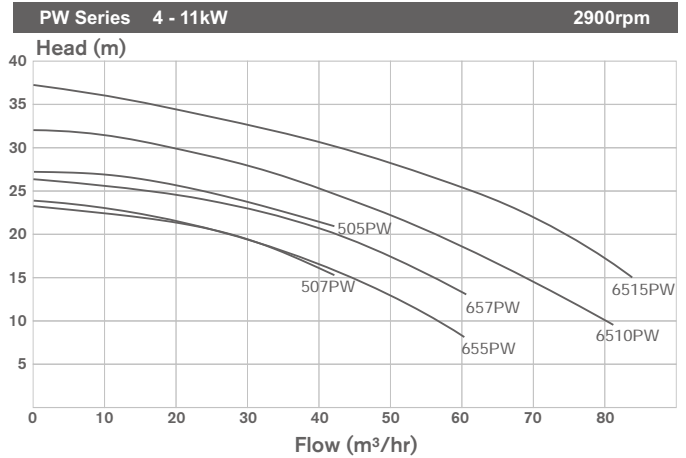
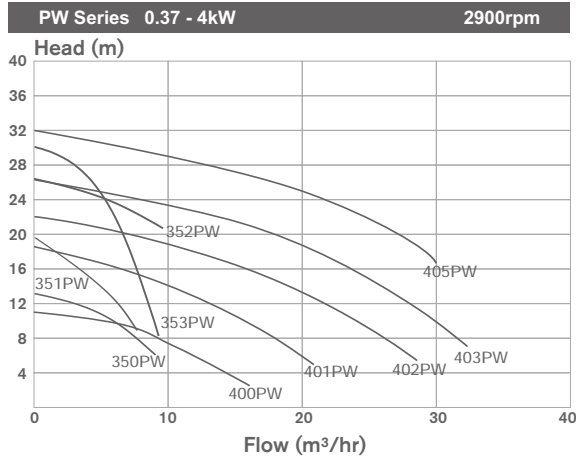

Dimensions

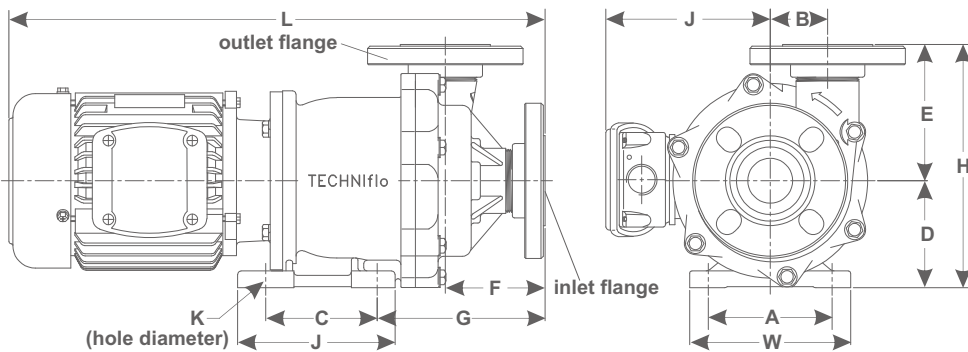

NOTE:
Explosion-proof motors available on request.
Motor dimensions may vary slightly depending on type used.
All dimensions in millimetres.

Model	W	H	L	A	B	C	D	E	F	G	J	K	inlet/outlet	motor size
350PW/-F	157	257	472	130	77.5	130	115	142	88	161	181.5	12	25/25	0.37kW
351PW/-F	160	257	470	130	77.5	130	115	142	88	170	181.5	12	25/25	0.75kW
352PW/-F	160	242	454.5	130	57	130	120	122	78	155	177.5	12	32/32	1.5kW
353PW/-F	160	242	454.5	130	57	130	120	122	78	155	177.5	12	32/32	2.2kW
400PW/-F	140	216	394	110	51	98	95	121	87	150	125	12	40/40	0.37kW
401PW/-F	160	254	488	130	57.5	130	115	139	102.5	184	148	12	40/40	0.75kW
402PW/-F	260	255	551	208	65	200	115	140	89	158	158	14	50/40	1.5kW
403PW/-F	260	255	591	208	65	200	115	140	89	158	158	14	50/40	2.2kW
405PW/-F	260	270	617	208	65	200	130	140	89	158	158	14	50/40	4.0kW
505PW/-F	260	319	650.5	220	60	300	162	157	89.5	123.2	360	14	65/50	4.0kW
507PW/-F	260	319	676.5	220	60	300	162	157	89.5	123.2	360	14	65/50	5.5kW
655PW/-F	260	360	715	210	85	270	175	185	118	240	158	14	80/65	4.0kW
657PW/-F	260	360	746	210	85	270	175	185	118	240	249	14	80/65	5.5kW
6510PW/-F	260	360	746	210	85	270	175	185	118	240	249	14	80/65	7.5kW
6515PW/-F	350	385	904	300	85	270	200	185	118	240	287	14	80/65	11.0kW

PW-N Series Self-Priming Magnetic Drive Pumps

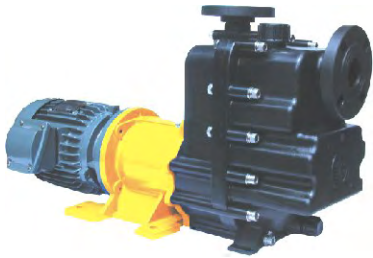

Typical Applications

- Heavy-duty reinforced polypropylene construction
- Advanced design with gas and water separation chamber
- Available in 5 models with max flow rate of 510 L/min
- Max suction lift 4 m
- Adaptable with standard IEC motor

Performance Curve

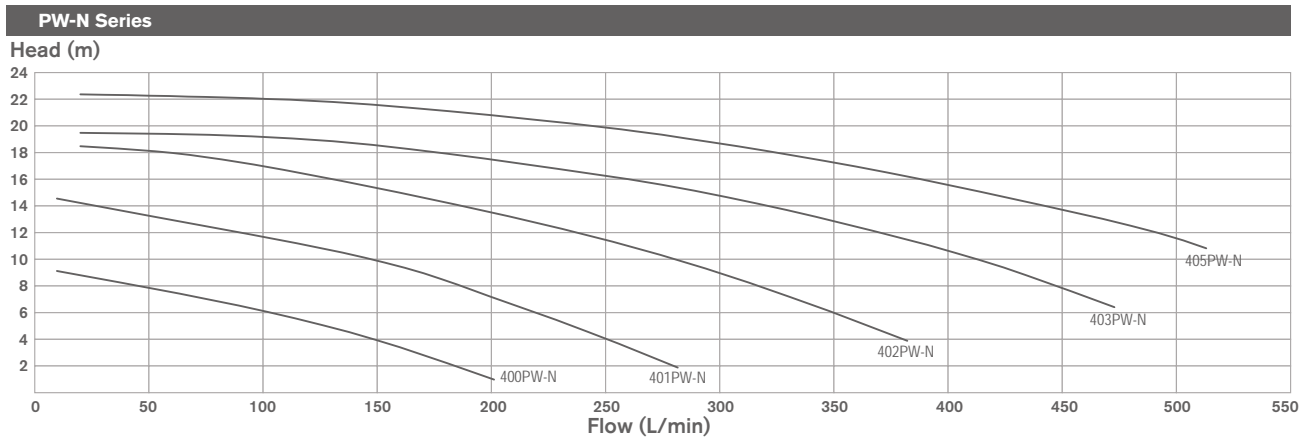

Dimensions

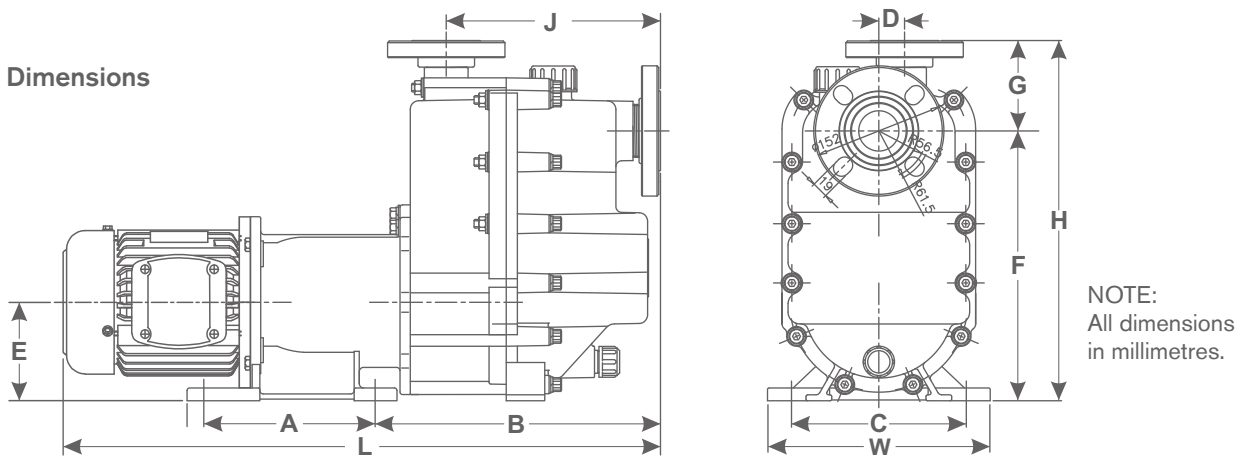

Model	A	B	C	D	E	F	G	H	J	K	L
400	130	308	130	20	115	285	105	390	212	613	160
401	130	308	130	20	115	285	105	390	212	315	160
402	200	333	208	30	115	315	105	420	250	762	260
403	200	333	208	30	115	315	105	420	250	762	260
405	200	333	208	30	130	330	105	435	250	866	260

PX & PS Series

Typical Applications

- Etching machines
- Laboratory applications
- Fume Scrubbers
- Sampling Analysers
- Filtration equipment
- Circulation Systems

Technical Features

- Polypropylene and ETFE wet ends
- Closed-coupled motors
- Flows up to 120 L/min
- Heads up to 20 m
- Liquid SG up to 1.8
- Liquid temperatures
 - 70°C for polypropylene
 - 90°C for ETFE
- Self-priming option on most models
- Brushless DC motor versions available with inbuilt 4-20mA control options.



PX Self-Priming Versions



PX & PS Series

Performance Curve

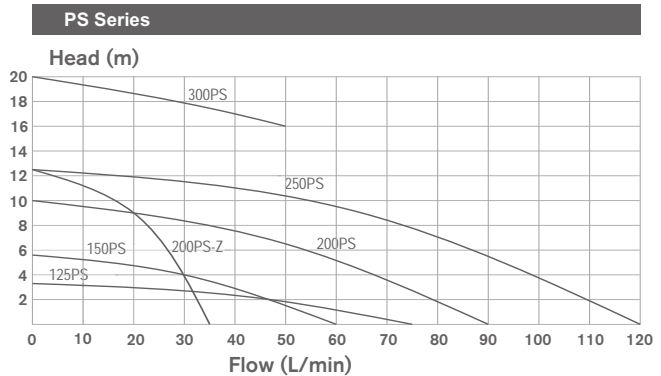
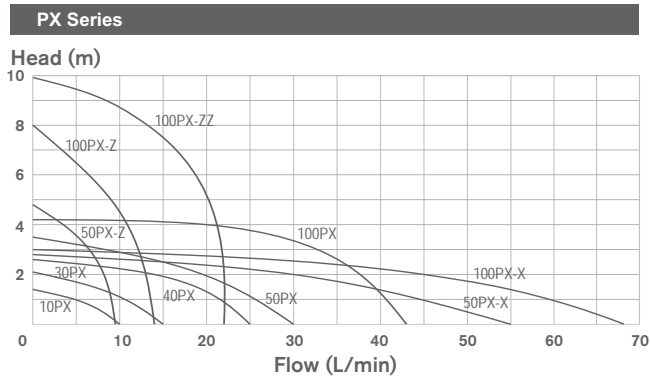

Dimensions

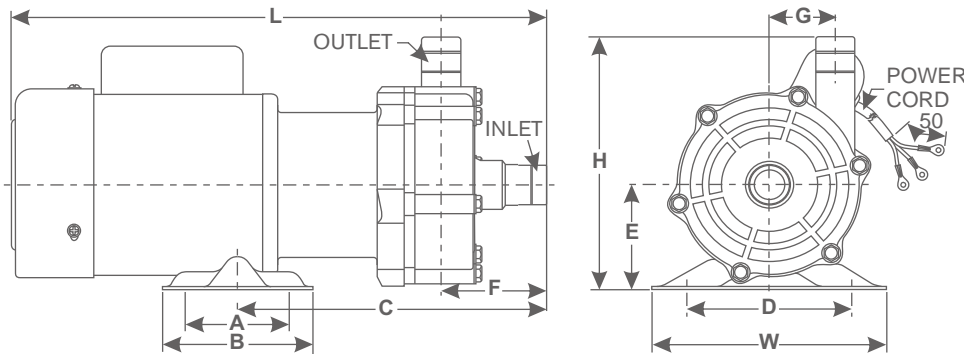

NOTE: Pump models with suffix '.3' have 3-phase motor (eg 200PS.3). Standard hose tail ports with BSP male thread option. All motors are IP44 except IEC versions. All dimensions in millimetres.

Model	W	H	L	A	B	C	D	E	F	G	inlet/outlet	motor size
10PX	74	92	145	-	30	73	60	45	31	17	12	5W
30PX	95	115	197	30	50	117	85	55	39	21.5	12	10W
40PX	95	115	210	30	50	131.5	68	55	38.5	28.5	16	20W
50PX-Z	95	125	226	30	50	134	68	55	39.5	38.5	16	20W
50PX	120	130	247	40	64	169	64	60	48	31	20	45W
50PX-X	120	135	255	40	64	176.5	64	60	50	26	25	45W
100PX-Z	120	130	236	40	64	152	64	60	39.5	38.5	16	45W
100PX	120	130	262	40	64	169	64	60	48	31	20	70W
100PX-X	120	135	270	40	64	176.5	64	60	50	26	25	60W
100PX-ZZ	120	150	243.5	40	64	160	64	60	38.5	44.5	16	70W
125PS	120	135	255	43	62	175	62	60	50	26	20	70W
150PS	120	164	300	40	64	200	100	66	70	43.5	20	90W
200PS	156	165	355	70	100	205	110	66	70	43.5	25	150W
200PS-Z	156	165	355	70	100	205	110	66	70	43.5	25	150W
250PS	156	165	365	70	100	195	110	66	70	43.5	25	250W
250PS-IEC	164	195	424	95	140	173	134	87	80	43.5	25	250W
300PS	160	175	385	80	110	230	140	75	55	59	25/20	300W

Accessories



Heat Jacket - For low temperature environments

Power Monitors - Early warning alarms to prevent pump damage

Low Flow - This option can save you energy

Vertical Configuration - Same pumping power with a smaller footprint

Custom Base Plates - Excellent for corrosion resistance, thermal stability, and vibration dampening

Alternate Casings - Ideal for non-standard installs

Drain Adaptor - Allows versatility of connection to the pump drain

Remote Pumping - Excellent for loading and unloading tanker trucks and pumping in remote locations

Self-Priming Tanks - Specially lined to be corrosive resistant

Chemical Mixers

PA Series

- 240V TEFC Motor
- Polypropylene Flange mount
- 4 bolt
- Available in PVDF or 316
Stainless Steel wetted materials
- Effective mixing for a wide range
of dosing chemicals



Drum Pumps



- Lightweight pumps designed for portable and static use
- Electric powered or compressed air powered motors available
- In a range of different materials including: PP, PVDF, SS and Aluminium
- To suit a wide range of containers from 20 litres to 1000 litres

Chemical & Process Pump Range

Stock Availability

- A comprehensive range of pumps & spares are held in stock to meet immediate requirements.

Expertise

- Trained and experienced product specialists with expertise in handling the complete range of Techniflo products.

Technical Support

- Full technical information covering all aspects of pump performance including compatibility with materials and systems design.

Advice

- Reliable advice regarding pump unit assembly, installation, operation, preventative maintenance programming and spare parts inventory.

Service Support

- Full repair and service capabilities including scheduled servicings.

Quality Control

- Techniflo pumps are manufactured strictly in accordance with the requirements of ISO 9001:2008 to ensure the highest levels of product quality.

Available from

